



GREENWOOD ACADEMIES TRUST

**Accessibility Plan for**  
**Mansfield Primary**  
**Academy**

Geoff Slade  
Harry Segrove  
Reviewed by David Jane and SLT : 24.02.2022

## Introduction

*Improving the physical environment of academies to enable those with disabilities to take better advantage of education, benefits, facilities and services provided*

1. This Accessibility Plan has been drawn up in consultation with the Greenwood Academies Trust Board, pupils, parents, staff and Advisory Councillors of the Academy and covers the period from February 2020 – February 2023.
2. We are committed to providing a fully accessible environment which values and includes all pupils, staff, parents and visitors regardless of their education, physical, sensory, social, spiritual, emotional and cultural needs. We are committed to challenging negative attitudes about disability and accessibility and to developing a culture of awareness, tolerance and inclusion.
3. The Greenwood Academies Trust (GAT) plans, over time, to increase the accessibility of provision for all pupils, staff and visitors to all of our sites. Individual Accessibility Plans are produced for each Academy and contain relevant actions to:
  - a. Improve access to the physical environment of the Academy, adding specialist facilities as necessary. This covers improvements to the physical environment and physical aids to access education.
  - b. Increase access to the curriculum for pupils with a disability, expanding the curriculum as necessary to ensure that pupils with a disability are as equally prepared for life as are the able-bodied pupils. This covers teaching and learning and the wider curriculum of the Academy such as participation in after school clubs, leisure and cultural activities, off site visits etc. It also includes the provision of specialist aids and equipment, which may assist disabled pupils in accessing the curriculum.
  - c. Improve the delivery of written information to pupils, staff, parents and visitors with disabilities. This will include handouts, timetables, textbooks and information about the Academy and its events. The information will be made available in various preferred formats within a reasonable time frame.
4. Attached are Action Plans, relating to these key aspects of accessibility. The plans will be reviewed and adjusted on an annual basis. New Action Plans will be produced every three (3) years.
5. We acknowledge that there is a need for ongoing awareness raising and training for staff, Trustees and Advisory Councillors in the matter of disability discrimination and the need to inform attitudes on this matter.
6. The Accessibility Plan should be read in conjunction with the relevant sections of following documents:
  - SEN and Disability Policy
  - Admissions Policy
  - Pupil Behaviour and Exclusions Policy
  - Every Child Matters

- Organisation of Pupil Learning
  - Education Brief
  - Academy Improvement Plans
  - Academy Brochures
  - Asset Management Plan
7. The Action Plan for physical accessibility relates to the Access Audit of the Academy, which is undertaken regularly by the Health and Safety Team. It may not be feasible to undertake some of the works during the life of this first Accessibility Plan and therefore some items will roll forward into subsequent plans. The audit will be reviewed prior to the end of each three year plan period in order to inform the development of the new Plan for the following period.
  8. As curriculum policies are reviewed, a section relating to access will be added to that on Equality and Diversity. The terms of reference for the GAT Finance and General Purposes (F&GP) and Advisory Council committees will contain an item on 'having regard to matters relating to Access'.
  9. The Academy Brochure will make reference to this Accessibility Plan.
  10. The Academy's Complaints Procedure covers the Accessibility Plan.
  11. Information about our Accessibility Plan will be published in each Academy's Annual Report to Parents (statutory).
  12. The Plan will be monitored through the Academy Advisory Council. Each Council will produce a termly report on progress against the plan for the GAT F&GP.
  13. The Academy will work in partnership with all stakeholders in developing and implementing this plan.
  14. The Plan will be monitored by Ofsted as part of their inspection cycle

## **Resources**

Building Bulletin 102: Designing for disabled children and children with special educational needs.

Building Bulletin 103: Area guidelines for Mainstream Schools.

Approved Document M

[https://www.gov.uk/government/uploads/system/uploads/attachment\\_data/file/540330/BR\\_PDF\\_AD\\_M1\\_2015\\_with\\_2016\\_amendments\\_V3.pdf](https://www.gov.uk/government/uploads/system/uploads/attachment_data/file/540330/BR_PDF_AD_M1_2015_with_2016_amendments_V3.pdf)

Gov.Uk Fire Safety Risk Assessment- Escape for Disabled People  
[https://www.gov.uk/government/uploads/system/uploads/attachment\\_data/file/422202/9446\\_Means\\_of\\_Escape\\_v2\\_.pdf](https://www.gov.uk/government/uploads/system/uploads/attachment_data/file/422202/9446_Means_of_Escape_v2_.pdf)

LABC Building Regulations in Practice - Accessible Toilets by David Spooner  
<http://www.gedling.gov.uk/media/documents/planningbuildingcontrol/LABCAccessible%20Toilet%20Diagram%20and%20Advice.pdf>

## Action summary

No	Issue	Action	Responsible Person	Completion date
1.	No disabled parking space	Create bay at side of hall.	The Principal	31.08.2022
2.	Reception area. There is no disabled push pad for disabled users to use to exit the building and the emergency exit button	Arrange to have a push pad installed at a height between 750mm and 1000mm above finished floor level so that it can be reached by a wheelchair user	The Principal	31.08.2022
3.	Staff accessible WC in KS1 corridor is non-compliant as it should have the following; <ul style="list-style-type: none"> <li>• Incorrect signage (does not indicate it is an accessible WC)</li> </ul>	Ensure the accessible WC is indicated by appropriate signage.	The Principal	31.08.2022
4.	It would be difficult for a visually impaired person to identify sockets and switches as they are the same colour as the wall surrounding them.	It is recommended that these are edged in a contrasting colour, such as the colour used for the door frames, to highlight their location.	The Principal	As and when required (Review 6 monthly)

# Physical accessibility

## Mobility Impairment



### Circulation routes

Someone who does not use a walking aid can manage to walk along a passageway less than 700mm wide, but just using a walking stick requires greater width than this; a minimum of 750mm. A person who uses two sticks or crutches, or a walking frame needs a minimum of 900mm, a wheelchair user and an ambulant person side-by-side need 1500mm width.

There is level access into the academy from the front and rear of the building. Paths onto and around the site are ramped where necessary. The Heritage building is not accessible

Pedestrian gates or entrances onto the grounds have a min clear opening width of 850mm

Disabled parking bay on a level and firm base as close as feasible to the main or an alternative accessible entrance to the building. Size of parking bay 4800mm x 2400mm with a 1200mm wide strip marked to the side and rear of the space for safe transfer into a wheelchair. All lines, hatching and symbols to be in yellow. A raised sign at the head of the bay to ensure that if snow or fallen leaves obscure the road markings, the purpose of the bay is still apparent.

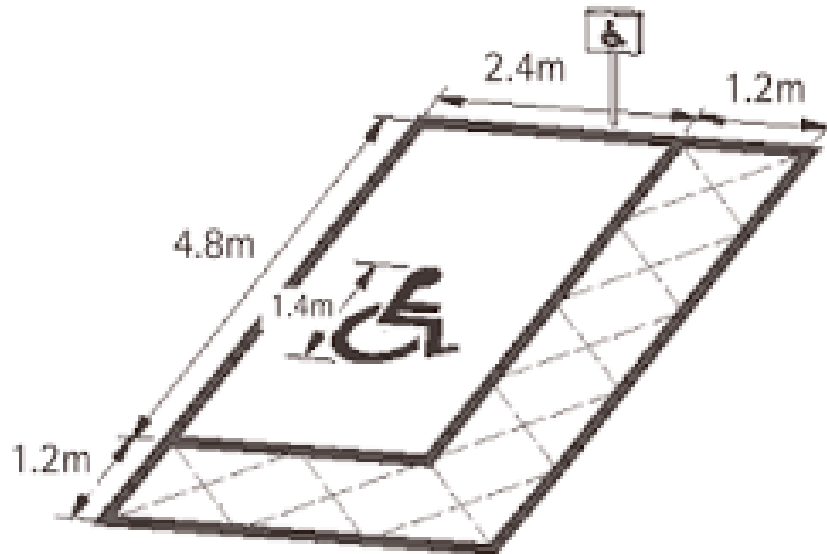

## COMMUNAL ENTRANCE AND RECEPTION AREAS

- Level or ramped access to entrance
- Door has a minimum width of 775mm
- Threshold is accessible (does not impede wheelchair access)
- Means to open the doors or doors are automatic
- Disabled push pad fitted to the inside of the main exit
- Reception lobby is wide enough to accommodate a wheelchair and companion.
- Counter: appropriate width & height, with adequate knee recess

## DINING AREAS

- Access to and from the dining area is suitable width for those with mobility impairment to move around.
- Furniture is suitable for use for those in a wheelchair and allows interaction between all pupils and staff whilst dining.

## Classrooms

Classrooms with a final exit have a wide door with a ramp for ease of exit in an emergency. Access routes around the classroom are wide enough to accommodate a wheelchair user.

## Visual Impairment

### LIGHTING AND CONTRAST

Lighting is suitable and sufficient  
Light sources do not create unnecessary shadows (shadows can  
Glare is avoided from shiny or glossy surfaces  
Light levels through different rooms and levels are equal  
Walls, floors and doorways are of contrasting colours.  
Colour scheme is simple and number of colours used is limited  
Wooden door and frame and dark carpeted floor tiles contrast against white walls



create optical illusions)

### CIRCULATION ROUTES

A blind person using a long cane or with an assistance dog needs a walkway measuring at least 1100mm. A visually impaired person who is being guided needs a width of at least 1200mm.

All nosings are made apparent by means of a permanently contrasting material 55mm wide on both the tread and the riser across their full width to help visually impaired people identify the location of each step.

Handrails are easily distinguishable from the background through the use of good visual contrast and have features to prevent guide dogs from walking under the rails, but with sufficient openings between vertical members to ensure that children and wheelchair users can see, and be seen, through the railings.

Unobstructed height above a pedestrian way is also important, especially for visually impaired people. This should be a minimum of 2300mm. Where a sign is suspended over a walkway a minimum clearance of 2100mm is acceptable. Where trees overhang a walkway it is advisable to cut them back to at least 3000mm clear height to allow room for regrowth

## Hearing Impairment

Visual alarms such as beacons are mounted at a minimum height of  
attract attention



2.1m from floor level, in a position that is likely to

Visual alarms (beacons) are installed where those with hearing impairment might be alone, such as accessible toilets



# Curriculum accessibility

At Mansfield Primary Academy our intention is to ensure that all pupils including pupils with special educational needs and/or disabilities develop a love for learning. All vulnerable pupils and pupils with special educational needs and or disabilities are supported to access the curriculum in full using varied resources. Our intention is to equip our children with all the skills they need to explore and master the skills required to help them achieve their dreams through an enriched curriculum. We pride ourselves on ensuring all pupils develop high levels of respect, responsibility, and resilience. Through the use of high-quality planning teaching and provision we are able to;

- Identify the needs of pupils early allowing early intervention to take place and ensure that progress is maximised to its full potential.
- Provide all pupils with the tools and skills they need to become independent and inquisitive both in and outside of the classroom environment.
- Ensure that all pupils have access to a rich and vibrant curriculum which is ambitious and engaging
- Provide a safe and stimulating environment which is accessible to all pupils and tailored to the individual needs.
- Regularly monitor the progress of children with SEND.
- Provide good quality and relevant training for all staff members supporting children with SEND.
- Work closely with external agencies and other professionals to hone and develop our provision for children with SEND.
- Include and value the contribution of all families to our understanding of equality and diversity.
- Ensure that Inclusion is embedded through all of our practise.

Inclusion is key within a child's education and life. We believe that inclusion is threaded through our curriculum in all areas to provide every child with the opportunity to flourish not only within their academic skills but also within their social and emotional skills. At Mansfield Primary Academy every teacher is a teacher of SEND and every leader is a leader of SEND meaning that we all foster the same values and ethos needed to support pupils in school and within the community. These values and beliefs are share with and enhanced by senior leaders, teachers, support staff, external agencies, parents and most importantly, the child.

At Mansfield Primary Academy, pupils with SEND will:

- Be included in all aspects of the school day.
- Be provided with quality first teaching, differentiated to their needs.
- Be respected and their contributions valued and acknowledged.
- Be included in extra curricular activities
- Develop the skills needed to become respectful, Responsible and Resilience both within their learning and life skills

At Mansfield Primary Academy a pupil with SEND may have:

- Specific 1:1 or small group intervention to support their academic, physical and social/emotional needs
- Use individual resources to enable them to access the curriculum, or the school day including the use of additional technology including dictate, immersive reader, clicker app and any other specific programme to support the needs of pupils.
- Access to a highly differentiated curriculum, tailored to very specific needs.

- Pupils with impairments by using a range of methods including coloured backgrounds, enlarging print, use of Makaton, radio waves alongside any other resources to enable learner to take a full active role in the curriculum.
- Take part in social and emotional support interventions, such as ELSA, Queen Bees or Lego Therapy
- Receive additional support for speech and language needs, working on targets set by specialist therapists
- Carry out some of their learning in low distraction areas, support by the schools learning support assistants or class teachers.
- Attend SEND extra-curricular events led by school or external agencies including TB sports or Brunts.
- Work alongside external agencies such as an Educational Psychologist, communication and interaction team, SFSS, Cognition and learning team, Speech and Language Therapist, Occupational Therapist, CAMHS, MHST, or Teacher of the Deaf, to develop specific targets/programmes tailored to the child's individual needs.
- Participate in additional SAP interventions including counselling, forest schools or drawing and talking therapy.

As a result of an inclusive and accessible school and curriculum with high quality provision in place all children at Mansfield Primary Academy will

- Become respectful, responsible and resilient learners
- Feel safe, happy and secure within their environment
- Display exemplary behaviours that demonstrates positive attitudes towards learning
- Demonstrate an enthusiastic attitude towards learning whereby they flourish both in and outside of the classroom environment
- Develop the independence skills required to help them achieve their dreams
- Develop their communication and interaction skills
- Develop strategies to help support their social and emotional health alongside develop strategies to support their mental wellbeing.
- Make good progress across all areas from their unique starting points through the use of personalised interventions.
- Develop the essential skills required to develop and maintain good independence and life skills in secondary school.